

电机性能规格
MOTOR PERFORMANCE SPECIFICATION

法兰 FLANGE	110
额定功率(W) RATED POWER	1800
额定电压(V) RATED VOLTAGE	AC220
每相感应电压常数(mV/(r/min)) INDUCED VOLTAGE CONSTANT PER PHASE	*A
额定电流(A) RATED CURRENT	9.5
瞬时最大电流(A) INSTANTANEOUS MAXIMUM CURRENT	29
额定转矩(N.m) RATED TORQUE	5.73
瞬时最大转矩(N.m) INSTANTANEOUS MAXIMUM TORQUE	17.2
相q轴电感(mH) Q PHASE-AXIS INDUCTANCE	*A
相d轴电感(mH) D PHASE-AXIS INDUCTANCE	*A
线圈电阻(Ω) COIL RESISTANCE	*A
线圈电感(mH) COIL INDUCTANCE	*A
额定转速(rpm) RATED ROTATION SPEED	3000
最高转速(rpm) MAXIMUM ROTATION SPEED	5000
转子转动惯量无刹车(10 ⁻⁴ kg.m ²) ROTOR MOMENT OF INERTIA WITHOUT BRAKE	8.6
转子转动惯量带刹车(10 ⁻⁴ kg.m ²) ROTOR MOMENT OF INERTIA WITH BRAKE	9.7
转子极对数P NUMBER OF ROTOR POLES P	5
定子槽数S NUMBER OF STATOR SLOTS S	12
编码器类型 ENCODER RESOLUTION	17bit
电机绝缘等级 MOTOR INSULATION LEVEL	F
电机防护等级 MOTOR PROTECTION LEVEL	IP67

轴端面局部:

Shaft-end dimension:

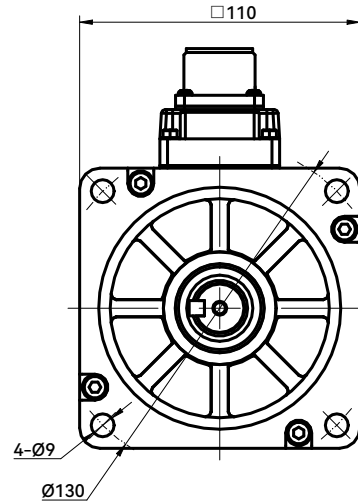
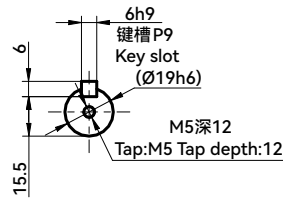

信号线插头:
Encoder connector:

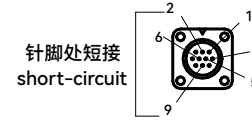

制动器插头:
Brake connector:

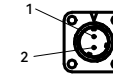

动力线插头:
Power connector:

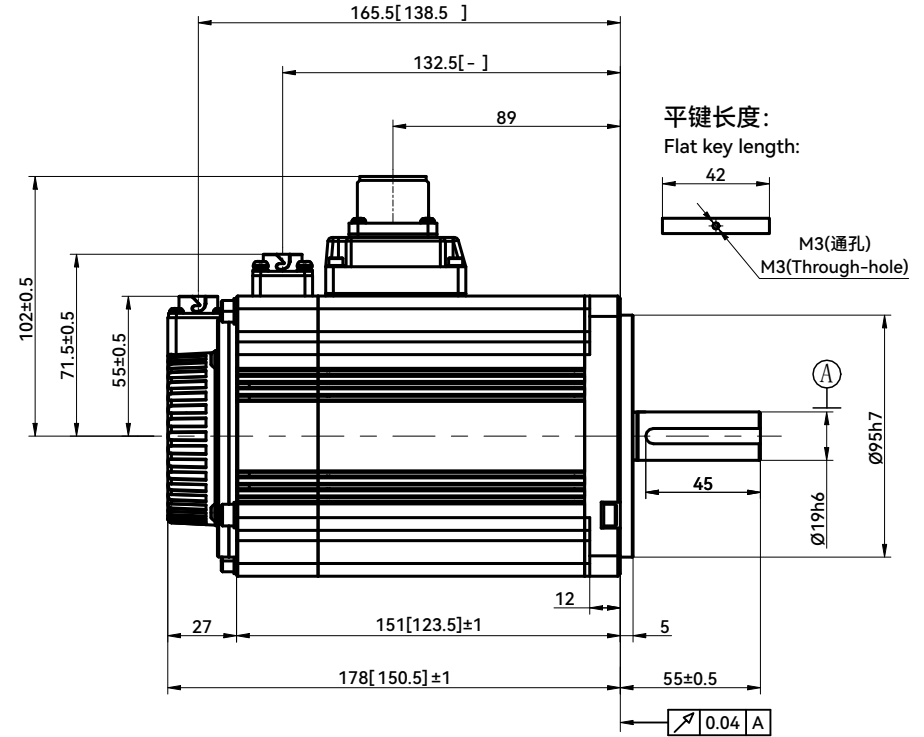
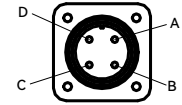

平键长度:
Flat key length:



M3(通孔)
M3(Through-hole)

信号线连接

Encoder connector

端子号码 TERMINAL NUMBER	信号名 SIGNAL NAME	备注 NOTE
1	VCC	
2	GND	
3	-	
4	BATT	
5	+DO	
6	-DO	
7	-	
8	-	
9	BAT-	
10	-	

动力线连接

Power connector

端子号码 TERMINAL NUMBER	信号名 SIGNAL NAME	备注 NOTE
A	U	
B	V	
C	W	
D	FG	

制动器连接

Brake connector

端子号码 TERMINAL NUMBER	信号名 SIGNAL NAME	备注 NOTE
1	BRK1	
2	BRK2	

注: 1. 方形括号内尺寸为不带刹车机种长度;
2. *A处详细参数请咨询我司技术人员。

Note: 1. Dimensions in brackets are for non-brake type length;
2. Please consult our technical personnel for detailed parameters at location *A.

客户回签
Customer signature

标记 MARK	处数 NUMBER OF REVISED	分区 SECTION	更改文件号 REVISED DOCUMENT NUMBER	签名 SIGNATURE	年月日 DATE
设计 DESIGN	1	1	2023.6.25	标准化	
审核 VERIFY	1	1	2023.6.25		
工艺 CRAFT				批准	2023.6.25

阶段标记
STAGE MARKER

重量
WEIGHT

比例
SCALE

共张 第张
PAGE / ALTOGETHER PAGE

HCFA 浙江禾川科技股份有限公司
Zhejiang Hechuan Technology Co., Ltd

1800W伺服电机
1800W Servo motor

X2MA180E